

Directional valve 2-way/2-position

$Q_{\max} = 36 \text{ gpm}$, $p_{\max} = 5000 \text{ psi}$

pilot operated, poppet type, switching solenoid with emergency override

Type series: WR22O_DA-10...



- Screw-in cartridge valve
- For cavity DD
- All external parts with zinc-nickel plating according to DIN EN ISO 19598
- Installation in threaded port body type DD-12
- The slip-on coil can be rotated, and it can be replaced without opening the hydraulic envelope
- High pressure wet-armature solenoids
- Various plug-connector systems and voltages are available
- Seat tight shut-off
- No external pilot drain required
- High flow rates
- Low head loss
- Reliable switching, even after long dwell times
- With manual override
- Also available as stack valve

Description

The 2-way/2-position solenoid operated spool valves, series WR22_D... are size 10, two stage, screw-in valves with an M24×1.5 mounting thread. The main stage as well as the pilot stage are designed on the proven poppet seat design, which ensures that the cartridges are leak-tight from B to A. The straightforward design delivers an outstanding price/performance ratio and good pressure loss/volume flow ratings. All external parts of the screw-in valves are zinc-nickel plated and

are thus suitable for use in the harshest operating environments. The slip-on coils can be replaced without opening the hydraulic envelope and can be positioned at any angle through 360°. These valves are used in mobile and industrial applications where leak-tight shutoff functions are crucially important. Examples are where loads, tensions, or clamping forces must be held without leakage. For self-assembly, please refer to the section related data sheets.

Symbol

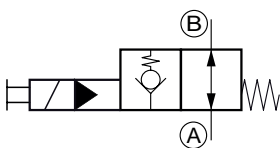

Technical data

General characteristics	Description, value, unit
Function group	Directional valve
Function	2-way/2-position
Design	Screw-in cartridge valve
Controls	switching solenoid with emergency override
Characteristic	pilot operated, poppet type
Construction size	NG 10
Thread size	M24×1,5
Mounting attitude	unrestricted
Weight	1.10 lb
Cavity acc. factory standard	For cavity DD
Tightening torque steel	48 ft·lb
Tightening torque aluminium	37 ft·lb
Tightening torque tolerance	± 10 %
Minimum ambient temperature	- 22 °F
Maximum ambient temperature	+ 122 °F
Surface protection	All external parts with zinc-nickel plating according to DIN EN ISO 19598
Sealing material	see ordering code
Seal kit order number	NBR: DS-276-N / FKM: DS-276-V

Hydraulic characteristics	Description, value, unit
Maximum operating pressure	5000 psi
Maximum flow rate	36 gpm
Flow direction	see symbol
Hydraulic fluid	HL and HLP mineral oil according to DIN 51 524; other fluids on request!
Minimum fluid temperature	- 22 °F
Maximum fluid temperature	+ 176 °F
Viscosity range	10 ... 500 mm ² /s (cSt)
Recommended viscosity range	15 ... 250 mm ² /s (cSt)
Minimum fluid cleanliness (cleanliness class according to ISO 4406:1999)	class 20/18/15

NOTE!

The switching safety of the valve is achieved by the volume flow and pressure drop (Δp).

Electric characteristics	Description, value, unit
Actuator type	solenoid coil
Solenoid coils type	D36
Supply voltage DC	12/24 V DC
Supply voltage AC	115/230 (50 ... 60 Hz) V AC
Supply voltage tolerance	± 10 %
Nominal power consumption	Version "E": V DC = 17 W / V AC = 17 W Version "N": V DC = 27 W / V AC = 25 W
Switching time	Version "E": 50...150 ms (energized) / 15...40 ms (de-energized) Version "N": 40...195 ms (energized) / 20...40 ms (de-energized)
Relative duty cycle	100 %
Electrical connection coil	several connection types available, see ordering code
Protection class solenoid coil to ISO 20 653 / EN 60 529	several classes of protection available, see ordering code (with appropriate mating connector and proper fitting and sealing)



NOTE!

The switching time can be strongly dependent on flow rate, pressure, oil viscosity and the dwell time under pressure. In practice, the switching time may therefore deviate from the specified value range.

Performance graphs

measured with oil viscosity 33.0 mm²/s (cSt), coil at steady-state temperature and 10 % undervoltage

$p = f(Q)$ Performance limit

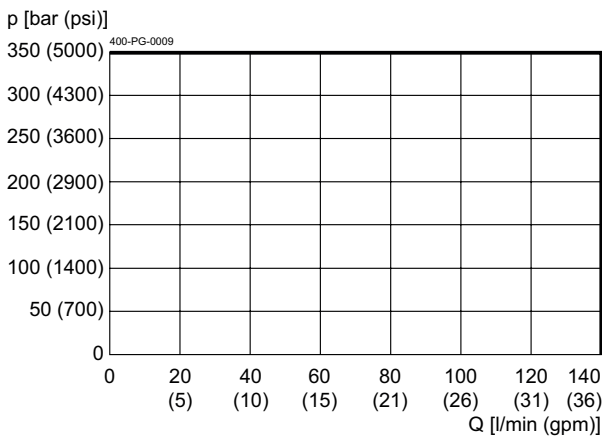

$\Delta p = f(Q)$ Pressure drop-flow rate characteristic

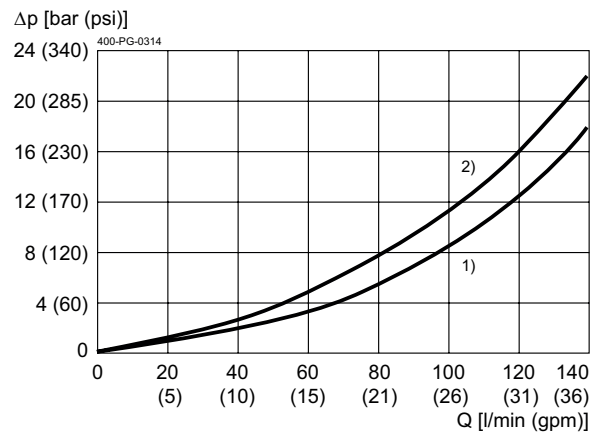

- 1) A → B, solenoid de-energizing
- 2) B → A, solenoid de-energizing

Dimensions and sectional view

Beispiel für die Masseinheit:
Example for the dimensional units:
0.79 = 0.79 mm millimeter
(.031) = 0.031" inch

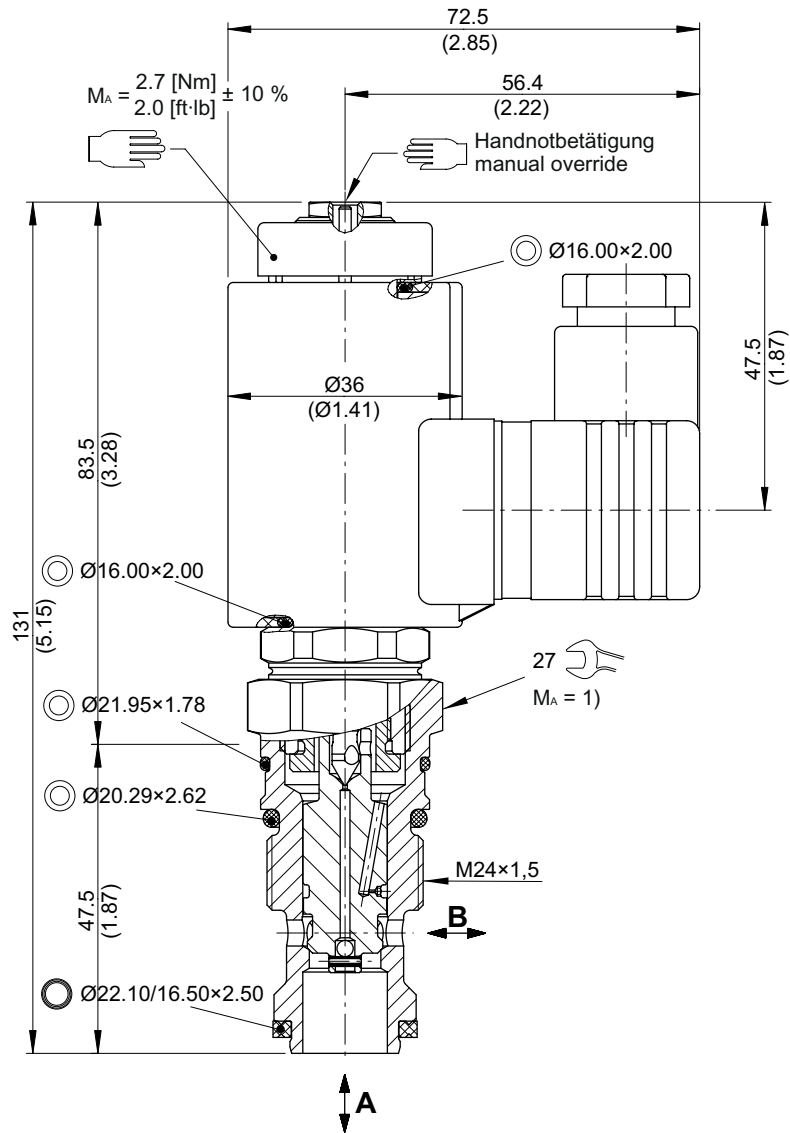

Installation information

i NOTE!
1) When fitting the screw-in cartridge valve, use the specified tightening torque. The value can be found in the chapter "Technical data".

i NOTE!
The seals are not available individually. The seal kit order number can be found in the chapter "Technical data".

! ATTENTION!
Only qualified personnel with mechanical skills may carry out any maintenance work. Generally, the only work that should ever be undertaken is to check, and possibly replace, the seals. When changing seals, oil or grease the new seals thoroughly before fitting them.

Ordering code

Ex. **W R 22O E D A - 10 - 5 24 D -**

- W = directional valve
- R = check valve function, pilot operated
- 22O = 2-way/2-position, normally open
- E = electrically operated, V DC = 17 W / V AC = 17 W (standard)
- N = electrically operated, V DC = 27 W / V AC = 25 W
- D = cavity type DD
- A ... Q = standard model according to valid data sheet (standard)
- Z ... R = special model after consultation
- 10 = nominal size 10
- (blank) = NBR (nitril-butadien-rubber / Buna) seals (standard)
- V = FKM (fluorocarbon rubber / Viton) seals (special seals - please consult BUCHER)
- 1 ... 9 = technical design no. (omit when ordering)
- ... = voltage e.g. 24 (24 V)
- D = current DC
- A = current AC
- (blank) = DIN EN 175301-803 connection, 3-pole 2 P+E with mating plug (IP 65) (standard)
- M100 = DIN EN 175301-803 connection, 3-pole 2 P+E
- C = Kostal plug connection (IP 65)
- JT = Junior Timer radial plug connection (with protection diode, IP 65)
- IT = Junior Timer axial plug connection (with protection diode, IP 65)
- D = Deutsch plug connection DT04-2P (IP 67/69K)
- DT = Deutsch plug connection DT04-2P (with protection diode, IP 67/69K)
- S = AMP Superseal 1.5 (IP 67) / Metri-Pack 150 (IP 65) plug connection
- F = flying leads (500 mm)

} mating plug not supplied

Related data sheets

Reference	Description
400-P-040011	Form tools
400-P-060121	CavityDD
400-P-740111	Threaded port bodyDD-12
400-P-120110	Solenoid coilD36

info.ch@bucherhydraulics.com

www.bucherhydraulics.com

© 2024 by Bucher Hydraulics AG Frutigen, 3714 Frutigen, Switzerland

All rights reserved.

Data is provided for the purpose of product description only, and must not be construed as warranted characteristics in the legal sense. The information does not relieve users from the duty of conducting their own evaluations and tests. Because the products are subject to continual improvement, we reserve the right to amend the product specifications contained in this catalogue.